

Type B4:

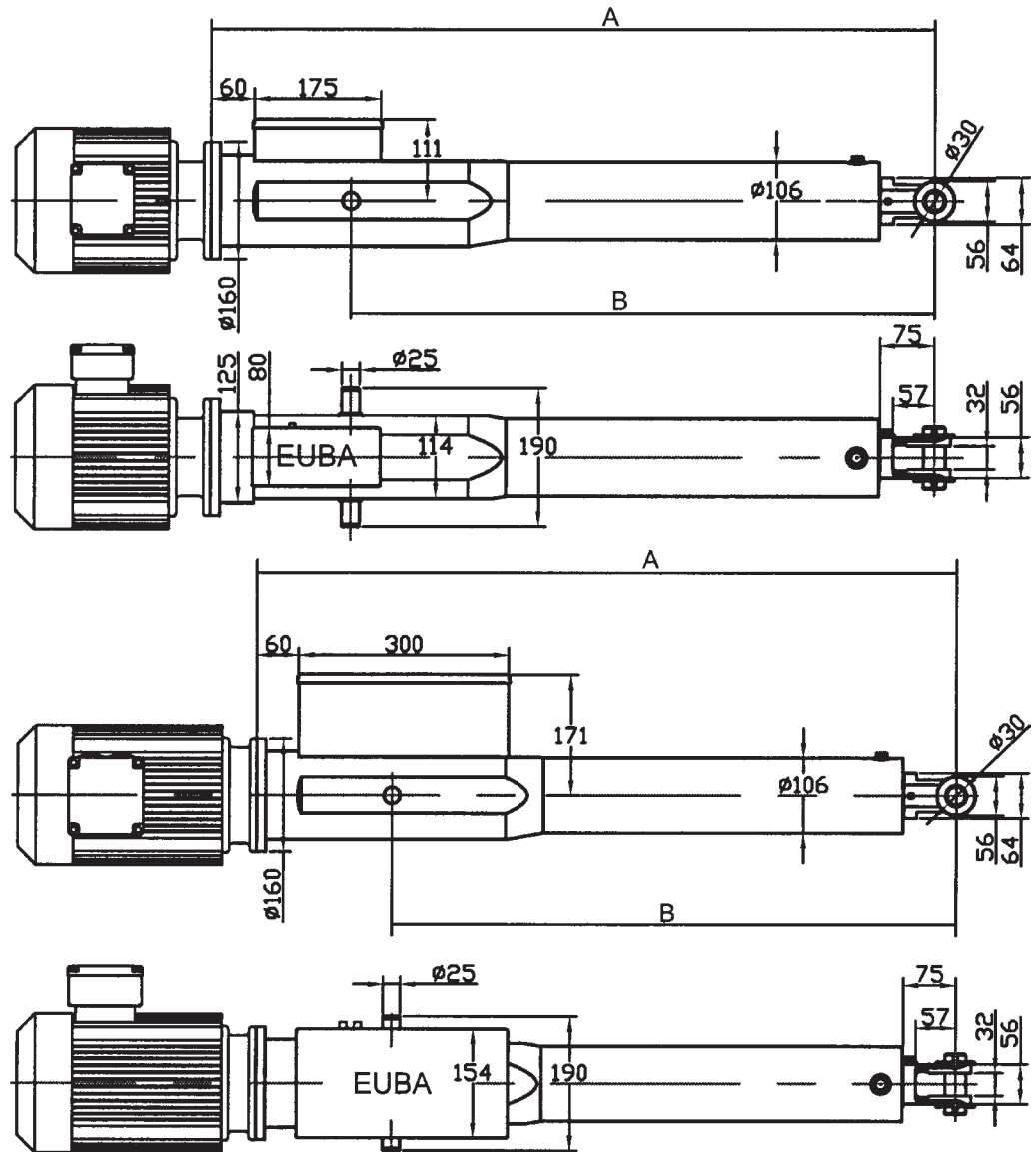

Mounting dimension actuator in mm													
stroke	0	50	100	150	200	250	300	350	400	450	500	550	600
A-size	502	552	602	652	702	752	802	852	902	952	1002	1052	1102
B-size	308	358	408	458	508	558	608	658	708	758	808	858	908
stroke	650	700	750	800	850	900	950	1000	1050	1100	1150	1200	1250
A-size	1152	1202	1252	1302	1352	1402	1452	1502	1552	1602	1652	1702	1752
B-size	958	1008	1058	1108	1158	1208	1258	1308	1358	1408	1458	1508	1558

Actuator dimensions can vary, especially the motor dimensions due to different brands.

B-size changeable

Motor dimensions depending on motor type and supplier

Power chart - Maximum force F [kN] related to stroke [mm]

Force F [kN]	5	10	15	20	25
Stroke s [mm]	1300	1050	850	750	650

Forces in between min. and max. can be realised continuously.

Standard design:

- Pivot
- Clevis

Special design:

- Brackets
- Foot mounting
- Cardan joint
- Special fixing
- Swivel head
- Angle ball - High temperature range up to +80°C
- Low temperature range down to -40°C
- Protection class up to IP-65
- ball screw spindle (KGT)

Actuator:

- Steel, with overload switches
- Acme screw thread spindle
- Spindle bearing system (overload protection unit), on both sides supported by spring piles
- Chrome plated push rod with internal torsion protection and scraper
- Temperature range from -10°C to +40°C

Motor:

Attachment of DIN IEC flange- and gear motors (manufacturer independent)

Clevis:

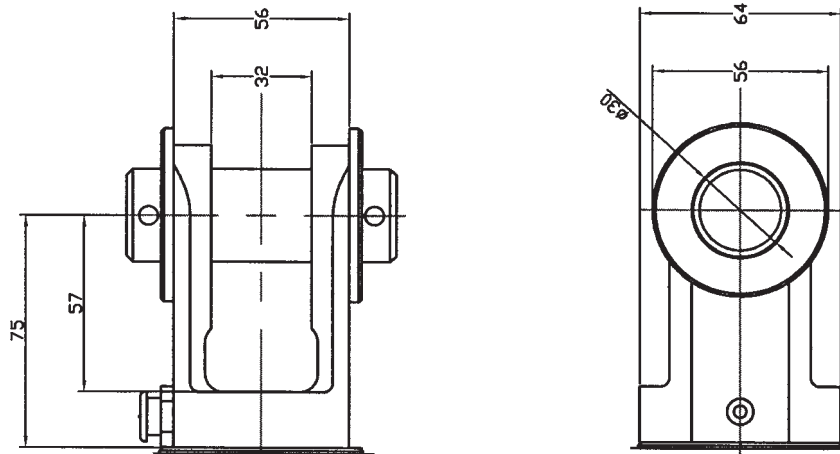

Cardan joint:

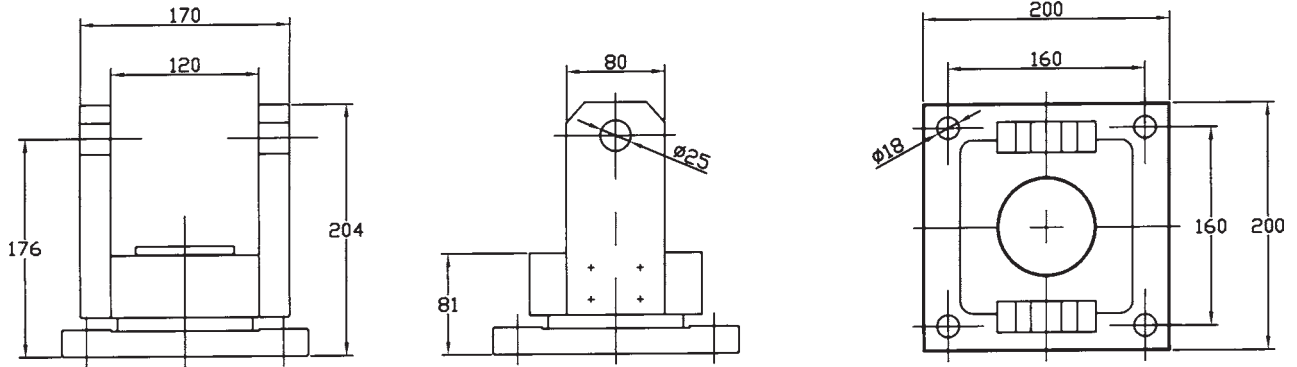

Brackets for pivot:

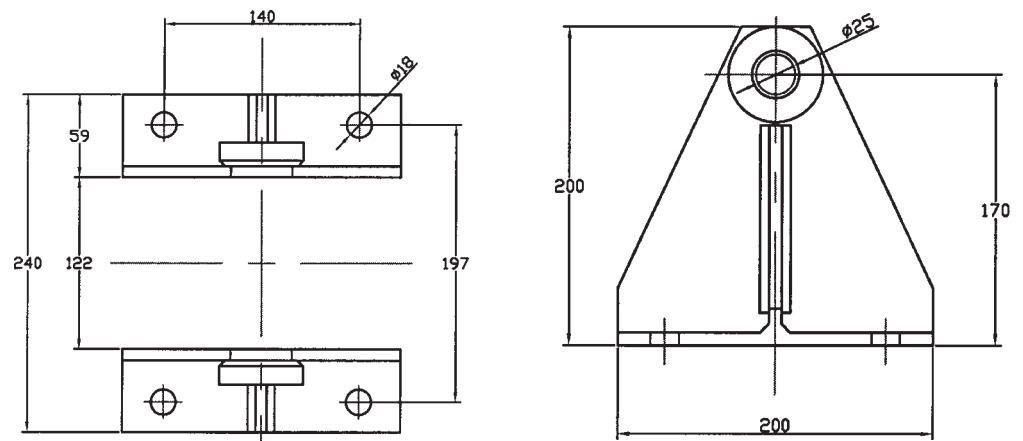

Swivel head

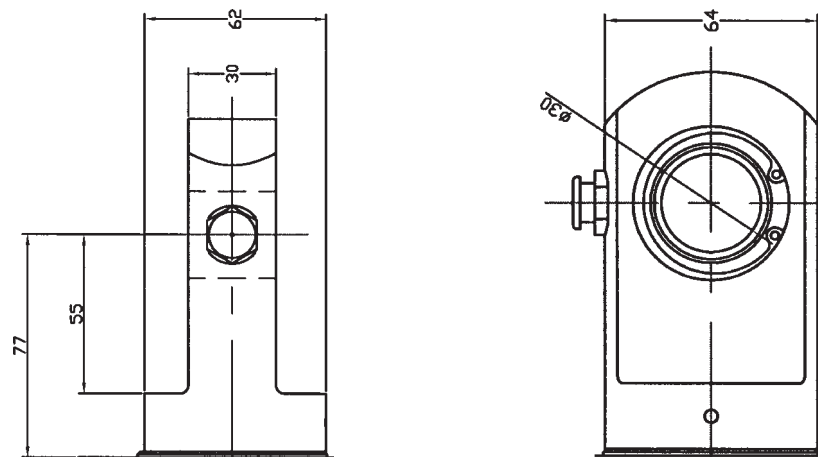

Please use the inquiry form for detailed technical specification.
Minor changes in dimensions are possible due to production tolerances.